

UNITED STATES DISTRICT COURT
SOUTHERN DISTRICT OF FLORIDA

CASE NO.: 24-cv-23973

THE KYJEN COMPANY, LLC,

Plaintiff,

v.

THE INDIVIDUALS, CORPORATIONS, LIMITED
LIABILITY COMPANIES, PARTNERSHIPS, AND
UNINCORPORATED ASSOCIATIONS IDENTIFIED
ON SCHEDULE A,

Defendants.

COMPLAINT

Plaintiff THE KYJEN COMPANY, LLC (“Plaintiff”) hereby alleges as follows against the individuals, corporations, limited liability companies, partnerships, and unincorporated associations and foreign entities identified on Schedule A¹ (collectively, “Defendants”).

INTRODUCTION

1. This is a civil action for trademark infringement and patent infringement to combat e-commerce store operators who trade upon Plaintiff’s reputation and goodwill by making, using, offering for sale, selling and/or importing into the United States for subsequent sale or use unauthorized and unlicensed products that infringe Plaintiff’s registered trademarks, as well as its designs for pet products in connection with Plaintiff’s patented designs.

2. Specifically, Defendants have infringed at least one of Plaintiff’s trademarks that are covered by U.S. Trademark Registration Nos. 3,281,982; 4,912,829; 2,709,593; 2,930,186; 3,278,965; 3,646,119; 4,514,817; 5,412,084; 5,428,383; 5,781,063; 5,781,065; or 6,301,802 (the

¹ Plaintiff intends to file a motion to file Schedule A under seal.

“Outward Hound Trademarks”) and/or at least one of Plaintiff’s design patents that are covered by U.S. Design Patent Nos. US D699,009 S; US D705,999 S; US D706,000 S; US D706,494 S; US D706,495 S; or US D706,001 S (the “Design Patents”) and/or at least one of Plaintiff’s utility patents that are covered by U.S. Patent Nos. US 8,316,804 B2, and US 9,756,835 B1 (the “Utility Patents”) (together the “Outward Hound Patents,” collectively with the Outward Hound Trademarks, the “Outward Hound IP”).

3. The Outward Hound Trademarks and the Outward Hound Patents are valid, subsisting, and in full force and effect. Plaintiff is the owner and lawful assignee of all right title, and interest in the Outward Hound IP. True and correct copies of the federal trademark registrations for the Outward Hound Trademarks are attached as **Exhibit 1**. True and correct copies of the Outward Hound Patents are attached as **Exhibit 2**.

4. Each Defendant directly and/or indirectly imports, develops, designs, manufactures, distributes, markets, offers to sell and/or sells products infringing Plaintiff’s Outward Hound IP (the “Infringing Products”) in the United States, including in this Judicial District, and otherwise purposefully directs infringing activities to this district in connection with the Infringing Products. By selling Infringing Products that purport to be genuine and authorized products using the Outward Hound IP, Defendants cause confusion and deception in the marketplace.

5. Defendants conduct this activity through their numerous fully interactive commercial Internet e-commerce stores operating under the online marketplace accounts identified in **Schedule A** attached hereto (collectively, the “Defendant Internet Stores”), including but not limited to the platforms Alibaba.com (“Alibaba”), Amazon.com (“Amazon”), DHgate.com

(“DHgate”), eBay.com (“eBay”), Shein.com (“Shein”), Temu.com (“Temu”), and Walmart.com (“Walmart”) (collectively, the “Marketplace Platforms”).

6. The Defendants design the online marketplace accounts to appear to be selling genuine products properly bearing, using, and sold utilizing the Outward Hound IP, while selling inferior imitations of such products.

7. The Defendant Internet Stores share unique identifiers, such as design elements and similarities of the counterfeit products offered for sale, establishing a logical relationship between them and that Defendants’ operation arises out of the same transaction, occurrence, or series of transactions or occurrences.

8. Defendants attempt to avoid and mitigate liability by operating under one or more seller aliases to conceal both their identities and the full scope and interworking of their operation.

9. Plaintiff is forced to file this action to combat Defendants’ infringement of its Outward Hound IP, as well as to protect unknowing consumers from purchasing Infringing Products over the Internet.

10. As a result of Defendants’ actions, Plaintiff has been and continues to be irreparably damaged through consumer confusion, dilution, and tarnishing of its valuable trademarks and goodwill. Plaintiff is further irreparably damaged from the loss of its lawful patent rights to exclude others from making, using, selling, offering for sale, and importing its patented design. Plaintiff therefore seeks injunctive and monetary relief.

SUBJECT MATTER JURISDICTION

11. This Court has original subject matter jurisdiction over the trademark infringement and false designation of origin claims in this action pursuant to the provisions of the Lanham Act, 15 U.S.C. § 1051 et seq., 28 U.S.C. § 1338(a)–(b), and 28 U.S.C. § 1331.

12. This Court has original subject matter jurisdiction over the patent infringement claim arising under the patent laws of the United States pursuant to 35 U.S.C. § 1 *et seq.*, §§ 271, 285, 283, 284, 285, 289, 28 U.S.C. § 1338(a), and 28 U.S.C. § 1331.

13. This Court has jurisdiction over the unfair deceptive trade practices claims in this action that arise under the laws of the State of Florida pursuant to 28 U.S.C. § 1367(a), because the state law claims are so related to the federal claims that they form part of the same case or controversy and derive from a common nucleus of operative facts.

PERSONAL JURISDICTION AND VENUE

14. Personal jurisdiction exists over Defendants in this Judicial District pursuant to 735 ILCS 5/2-209 or, in the alternative, Fed. R. Civ. P. 4(k) because, upon information and belief, each Defendant regularly conducts, transacts and/or solicits business in Florida and in this Judicial District, and/or derives substantial revenue from business transactions in Florida and in this Judicial District and/or otherwise avail themselves of the privileges and protections of the laws of the State of Florida such that this Court's assertion of jurisdiction over Defendants does not offend traditional notions of fair play and due process.

15. In addition, each Defendant has offered to sell and ship and/or sold and shipped Infringing Products into this Judicial District. Defendants' infringing actions caused injury to Plaintiff in Florida and in this Judicial District such that Defendants should reasonably expect such actions to have consequences in Florida and this Judicial District. For example:

a. Defendant Internet Stores accept orders of Infringing Products from and offer shipping to Florida addresses located in this Judicial District. Screenshots of the shopping cart from Defendant Internet Stores allowing Infringing Products to be shipped to River Forest and in this Judicial District are attached to the declaration of Evanka Herbers ("Herbers Decl."), filed

contemporaneously herewith, as **Exhibit 3**.

b. Upon information and belief, Defendants were and/or are systematically directing and/or targeting their business activities at consumers in the U.S., including those in Florida, in this Judicial District, through accounts (the “User Account(s)”) with online marketplace platforms such as Alibaba, Amazon, DHgate, eBay, Shein, Temu and Walmart, as well as any and all as yet undiscovered User Accounts with additional online marketplace platforms held by or associated with Defendants, their respective officers, employees, agents, servants and all persons in active concert or participation with any of them, through which consumers in the U.S., including Florida (and more particularly, in this Judicial District), can view the marketplace accounts that each Defendant operates, uses to communicate with Defendants regarding their listings for Infringing Products and to place orders for, receive invoices for and purchase Infringing Products for delivery in the U.S., including Florida (and specifically, in this Judicial District), as a means for establishing regular business with the U.S., including Florida (and specifically, in this Judicial District).

c. Upon information and belief, Defendants have transacted business with consumers located in the U.S., including Florida (and more particularly, in this Judicial District), for the sale and shipment of Infringing Products.

16. Venue is proper in this Court pursuant to at least 28 U.S.C. §§ 1391(b)(2) because Defendants have committed acts of patent infringement in this Judicial District, do substantial business in the Judicial District, and have registered agents in this Judicial District. Specifically, Defendants are reaching out to do business with Florida residents by operating one or more commercial, interactive Internet Stores through which Florida residents can purchase products infringing on the Outward Hound IP. Each Defendant has targeted sales from Florida residents by

operating online stores that offer shipping to the United States, including Florida and this Judicial District. Each Defendant is committing tortious acts in Florida, is engaging in interstate commerce, and has wrongfully caused Plaintiff substantial injury in the State of Florida.



THE PLAINTIFF

17. Plaintiff The Kyjen Company, LLC d/b/a Outward Hound is a limited liability company organized and existing under the laws of Colorado with its principal place of business in Centennial, Colorado. Plaintiff specializes and has specialized in the development and marketing of pet toys. Among other things, Plaintiff develops, manufactures, and markets pet products incorporating the Outward Hound IP (the “Outward Hound Products”).

OUTWARD HOUND IP AND PRODUCTS

18. Plaintiff is the owner and lawful assignee of all right title, and interest in and to the Outward Hound IP, including the following trademarks and patented designs:

U.S. Trademark Registration No.	Description	Registration Date
2,709,593	OUTWARD HOUND (word mark)	Apr. 22, 2003
2,930,186	PETSTAGES (word mark)	Mar. 8, 2005
3,278,965	Hide A Squirrel (word mark)	Aug. 14, 2007
3,646,119	Nina Ottosson (word mark)	June 30, 2009
4,514,817	DOGWOOD (word mark)	Apr. 15, 2014
5,412,084	Fun Feeder (word mark)	Feb. 27, 2018
5,428,383	Tower of Tracks (word mark)	Mar. 20, 2018
5,781,063	BEST FRIENDS BY SHERI (word mark)	June 18, 2019
5,781,065	DEEP DISH (word mark)	June 18, 2019
6,301,802	Wholesome Pride (word mark)	Mar. 23, 2021

U.S. Trademark Registration No.	Description	Registration Date
3,281,982	(Design mark) 	Aug. 21, 2007
4,912,829	(Design mark) 	Mar. 8, 2016

(See Ex. 1.)

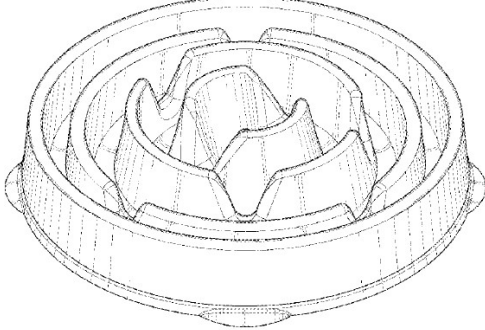
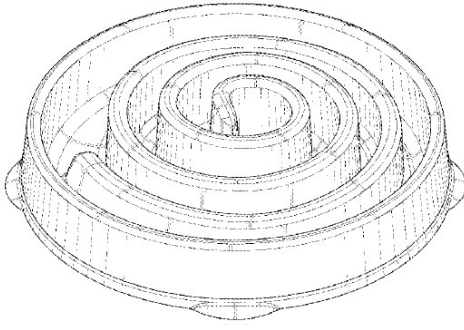
U.S. Patent Number	Claim	Issue Date
D699,009 S		Feb. 4, 2014
D705,999 S		May 27, 2014

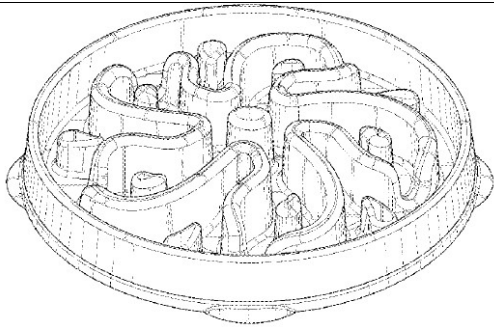
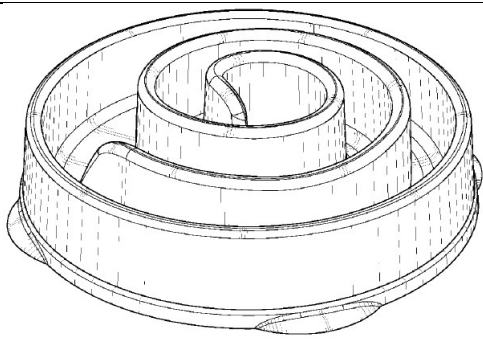
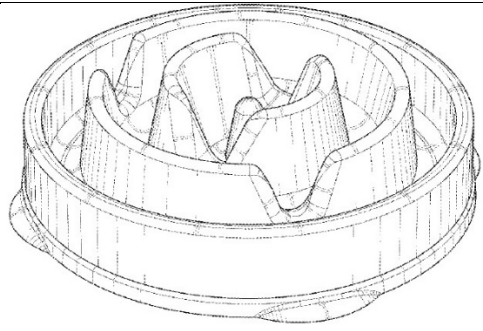
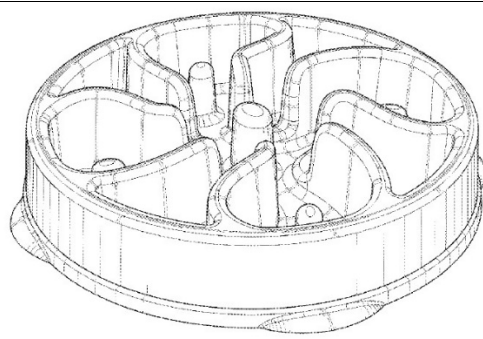
U.S. Patent Number	Claim	Issue Date
D706,000 S		May 27, 2014
D706,494 S		Jun. 3, 2014
D706,495 S		Jun. 3, 2014
D706,001 S		May 27, 2014
US 8,316,804 B2	Pet Game Board Detail and Board Game	Nov. 27, 2012

U.S. Patent Number	Claim	Issue Date
US 9,756,835 B1	Pet Memory and Agility Exercise Board Game	Sep. 12, 2017

(See Ex. 2.)

19. Since Plaintiff launched its Outward Hound Products in 2005, the company has followed a defined strategy for positioning its brand, marketing and promoting the products in the industry and to consumers, and establishing distribution channels. Plaintiff's promotional efforts of its Outward Hound Products include, by way of example but not limitation, substantial print media, the outwardhound.com and social media websites, point-of-sale materials, and exhibition booths at international trade shows such as Global Pet Expo, Interzoo (the world's biggest trade fair for pet supplies), and Superzoo (North America's largest pet retail event). Plaintiff has expended substantial time, money, and other resources in advertising and otherwise promoting its Outward Hound Products.

20. The superiority of the Outward Hound Products' innovative designs have been recognized by the industry, including recognition as Vendor of the Year 2022 from Pet Supplies Plus, and numerous recognitions and award for Plaintiff's Nina Ottosson brand, such as from Pet Age (2017 Industry Icon Award; 2015 Women of Influence Award), and the Pet Business Industry Recognition Awards (2020 Best Interactive Cat Toy).

21. Plaintiff's Outward Hound Products are distributed and sold to consumers throughout the world, including in the United States and Florida through authorized retailers, various affiliates, and the <http://outwardhound.com> website.

22. The Outward Hound Products have become enormously popular, driven by Plaintiff's arduous quality standards and innovative designs. Plaintiff's Outward Hound Products are known for their distinctive designs. These designs are broadly recognized by consumers as

being sourced from Plaintiff. Products fashioned after these designs are associated with the quality and innovation that the public has come to expect from the Outward Hound Products. Plaintiff uses these designs in connection with the Outward Hound Products, including, but not limited to, the Outward Hound IP.

23. Plaintiff is the official source of the Outward Hound Products, which include innovative dog games, dog toys, and slow feeder dog bowls, and single & limited-ingredient dog treats, beds for dogs and cats, and games and toys for cats, utilizing the Outward Hound IP, including:



Fun Feeder® Slow Bowl
(U.S. TM Reg. No. 5,412,084; at least U.S. Pat. No. D699,009 S)



Tower of Tracks® Cat Toy, Multi
(U.S. TM Reg. No. 5,428,383)



Deep Dish Cuddler Cat & Dog Bed, 20x20

more from [Best Friends By Sheri](#)

★★★★☆ 5 Reviews

~~\$29.99~~ - ~~\$32.99~~

 [Buy now, pay later. Learn more](#)

DESIGNED FOR ANIMALS LOVED BY PET PARENTS!
Cozy warm and comfortable a pet bed is a must-have for your four-legged friend. While many models promote better sleep they become flat and uncomfortable the...

[See Full Details](#)

Deep Dish® Cuddler Cat & Dog Bed
(U.S. TM Reg. Nos. 5,781,065)

[Home](#) / [Brands](#) / [Best Friends By Sheri](#) / [The Original Calming Donut Lux Cat & Dog Bed](#)



The Original Calming Donut Lux Cat & Dog Bed

more from [Best Friends By Sheri](#)

★★★★★ 6 Reviews

~~\$34.99~~ — ~~\$149.99~~ ~~\$29.99~~ - ~~\$99.99~~

 [Buy now, pay later. Learn more](#)

Give your pet more than just a dog bed! Best Friend's by Sheri is the original creator of the most popular dog bed that has surfaced the internet in recent years: The Calming Donut Dog Bed. This innov...

[See Full Details](#)

Best Friends By Sheri® The Original Calming Donut Lux Cat & Dog Bed
(U.S. TM Reg. No. 5,781,063)



Dogwood Wood Alternative Dog Chew Toy, Mesquite

more from [Petstages](#)

★★★★☆ 8 Reviews

~~\$8.99~~ — ~~\$21.99~~ ~~\$5.99~~ - ~~\$21.99~~

 [Buy now, pay later. Learn more](#)

A safe and long lasting alternative to chewing real wood sticks, Dogwood by Petstages has all the taste and texture of a natural tree branch, but will last much longer and won't splinter and make a me...

[See Full Details](#)

Petstages® Dogwood® Wood Alternative Dog Chew Toy
(U.S. TM Reg. Nos. 2,930,186, 4,512,817)

THE DEFENDANTS

24. Defendants are individuals and business entities who, upon information and belief, reside mainly in the People's Republic of China or other foreign jurisdictions. Defendants conduct business throughout the United States, including within Florida and in this Judicial District, through the operation of the fully interactive commercial websites and online marketplaces operating under the Defendant Internet Stores. Each Defendant targets the United States, including Florida, and has offered to sell and, on information and belief, has sold and continues to sell infringing Outward Hound Products to consumers within the United States, including Florida and in this Judicial District.

DEFENDANTS' UNLAWFUL CONDUCT

25. The success of the Outward Hound Products has resulted in a significant number of products that infringe the Outward Hound IP.

26. Plaintiff has identified numerous Defendant Internet Stores linked to fully interactive websites and marketplace listings on platforms such as Alibaba, Amazon, DHgate, eBay, Shein, Temu, and Walmart. These Defendant Internet Stores offer for sale, sell, and import Infringing Products to consumers in this Judicial District and throughout the United States.

27. Defendants have persisted in creating such online marketplaces and internet stores, like the Defendant Internet Stores. In fact, such online marketplaces and stores are estimated to receive tens of millions of visits per year and to generate over \$135 billion in annual online sales. According to an intellectual property rights seizures statistics report issued by the United States Department of Homeland Security, the manufacturer's suggested retail price of goods seized by the U.S. government in fiscal year 2021 was over \$3.3 billion. Internet websites like the Defendant Internet Stores are also estimated to contribute to tens of thousands of lost jobs for legitimate

businesses and broader economic damages such as lost tax revenue every year.

28. On personal knowledge and belief, Defendants facilitate sales by designing the Defendant Internet Stores so that they appear to unknowing consumers to be authorized online retailers, outlet stores, or wholesalers selling genuine Outward Hound Products. Many of the Defendant Internet Stores look sophisticated and accept payment in U.S. dollars via credit cards, Western Union, and PayPal. Defendant Internet Stores often include images and design elements that make it very difficult for consumers to distinguish such counterfeit sites from an authorized website.

29. Defendants further perpetuate the illusion of legitimacy by offering “live 24/7” customer service and using indicia of authenticity and security that consumers have come to associate with authorized retailers, including the McAfee® Security, VeriSign®, Visa®, MasterCard®, and PayPal® logos.

30. Plaintiff has not licensed or authorized Defendants to use the Outward Hound IP and none of the Defendants is an authorized retailer of genuine Outward Hound Products.

31. On personal knowledge and belief, Defendants also deceive unknowing consumers by using the Outward Hound Trademarks without authorization within the product descriptions, content, text, and/or meta tags of their websites to attract various search engines crawling the Internet looking for websites relevant to consumer searches for Outward Hound Products. Additionally, upon information and belief, Defendants use other unauthorized search engine optimization (“SEO”) tactics and social media spamming so that the Defendant Internet Stores listings show up at or near the top of relevant search results and misdirect consumers searching for genuine Outward Hound Products. Further, Defendants utilize similar illegitimate SEO tactics to propel new internet storefront listings to the top of search results after others are shut down. As

such, Plaintiff also seeks to disable the Defendant Internet Stores owned and/or operated by Defendants that are the means by which the Defendants could continue to sell Infringing Products into this Judicial District.

32. On personal knowledge and belief, Defendants have targeted sales to Florida residents by setting up and operating e-commerce stores that target United States consumers using one or more seller aliases, offer shipping to the United States, including Florida, accept payment in U.S. dollars and have sold Infringing Products to residents of Florida.

33. On information and belief, Defendants go to great lengths to conceal their identities and often use multiple fictitious names and addresses to register and operate their massive network of Defendant Internet Stores. For example, it is common practice for infringers to register their Defendant Internet Stores with incomplete information, randomly typed letters, or omitted cities or states, as Defendants here have done.

34. On personal knowledge and belief, Defendants regularly create new websites and online marketplace accounts on various platforms using the identities listed in Schedule A to the Complaint, as well as other unknown fictitious names and addresses. Such Defendant Internet Store registration patterns are one of the common tactics used by Defendants to conceal their identities, the full scope and interworking of their massive e-commerce operations, and to avoid being shut down.

35. On personal knowledge and belief, even though Defendants operate under multiple fictitious names, there are numerous similarities among the Defendant Internet Stores. For example, some of the Defendant Internet Stores have virtually identical layouts, even though different aliases were used to register the Defendant Internet Stores.

36. The Defendant Internet Stores also include other notable common features,

including accepted payment methods, check-out methods, meta data, illegitimate SEO tactics, HTML user-defined variables, domain redirection, lack of contact information, identically or similarly priced items and volume sales discounts, similar hosting services, similar name servers, and the use of the same text and images.

37. In addition to operating under multiple fictitious names, Defendants in this case and defendants in other similar cases against online counterfeiters use a variety of other common tactics to evade enforcement efforts. For example, infringers like Defendants will often register new online marketplace accounts under User Accounts once they receive notice of a lawsuit.²

38. Infringers also often move website hosting to rogue servers located outside the United States once notice of a lawsuit is received. Rogue servers are notorious for ignoring take down demands sent by brand owners.³

39. Further, infringers such as Defendants typically operate multiple credit card merchant accounts as well as e-commerce accounts, such as PayPal, behind layers of payment gateways so that they can continue operation in spite of Plaintiff's enforcement efforts.

40. On personal knowledge and belief, Defendants maintain off-shore bank accounts and regularly move funds from their e-commerce, PayPal, and other financial accounts to off-shore bank accounts outside the jurisdiction of this Court. Indeed, analysis of PayPal transaction logs from previous similar cases indicates that offshore counterfeiters regularly move funds from U.S.-

² See <https://www.ice.gov/news/releases/buyers-beware-ice-hsi-and-cbp-boston-warn-consumers-about-counterfeit-goods-during> (noting counterfeiters are “very adept at setting up online stores to lure the public into thinking they are purchasing legitimate good on legitimate websites”) (last visited October 14, 2024).

³ While discussed in the context of false pharma supply chains, rogue internet servers and sellers are a well-known tactic that have even been covered in congressional committee hearings. See <https://www.govinfo.gov/content/pkg/CHRG-113hrg88828/html/CHRG-113hrg88828.htm> (last visited October 14, 2024).

based PayPal accounts to foreign-based bank accounts outside the jurisdiction of this Court.

41. Defendants, without any authorization or license from Plaintiff, have knowingly and willfully used and continue to use the Outward Hound IP in connection with the advertisement, distribution, offering for sale, and sale of Infringing Products into the United States and Florida over the Internet.

42. Each Defendant Internet Store offers shipping to the United States, including Florida (in this Judicial District) and, on information and belief, each Defendant has offered to sell Infringing Products into the United States, including Florida (in this Judicial District), which is likely to cause and has caused confusion, mistake, and deception by and among consumers and is irreparably harming Plaintiff.

43. Prior to and contemporaneous with their infringing actions alleged herein, Defendants had knowledge of (i) Plaintiff's ownership of the Outward Hound IP, (ii) the fame and incalculable goodwill associated therewith, and (iii) the popularity and success of the Outward Hound Products. Defendants in bad faith proceeded to manufacture, market, develop, offer to be sold, and/or sell the Infringing Products.

44. Defendants have been engaging in the infringing actions, as alleged herein, knowingly and intentionally, or with reckless disregard or willful blindness to Plaintiff's rights, or in bad faith, for the purpose of trading on the goodwill and reputation of Plaintiff and the Outward Hound Products.

FIRST CAUSE OF ACTION
TRADEMARK INFRINGEMENT AND COUNTERFEITING (15 U.S.C. § 1114)

45. Plaintiff hereby re-alleges and incorporates by reference herein the allegations set forth in paragraphs 1–44 of this Complaint.

46. This is a trademark infringement action against Defendants based on their unauthorized use in commerce of Plaintiff's registered trademarks, Registration Nos. 3,281,982; 4,912,829; 2,709,593; 2,930,186; 3,278,965; 3,646,119; 4,514,817; 5,412,084; 5,428,383; 5,781,063; 5,781,065; or 6,301,802 (the Outward Hound Trademarks), in connection with the sale, offering for sale, distribution, and/or advertising of Infringing Products. The Outward Hound Trademarks are highly distinctive marks. Consumers have come to expect the highest quality from Plaintiff's products provided under the Outward Hound Trademarks.

47. Defendants have sold, offered to sell, marketed, distributed, and advertised, and are still selling, offering to sell, marketing, distributing, and advertising products in connection with the Outward Hound Trademarks without Plaintiff's permission.

48. Plaintiff is the registered owner of the Outward Hound Trademarks. The United States Registrations for the Outward Hound Trademarks (Exhibit 1) are in full force and effect. Upon information and belief, Defendants have knowledge of Plaintiff's rights in the Outward Hound Trademarks and are willfully infringing the Outward Hound Trademarks. Defendants' willful, intentional, and unauthorized use of the Outward Hound Trademarks is likely to cause and is causing confusion, mistake, and deception as to the origin and quality of the counterfeit goods among the general public.

49. Defendants' activities constitute willful trademark infringement and counterfeiting under 15 U.S.C. §§ 1114, 1117.

50. The injuries and damages sustained by Plaintiff have been directly and proximately caused by Defendants' wrongful reproduction, use, advertisement, promotion, offering to sell, and sale of counterfeit Outward Hound Products.

51. Plaintiff has no adequate remedy at law, and, if Defendants' actions are not enjoined, Plaintiff will continue to suffer irreparable harm to its reputation and the goodwill of its well-known Outward Hound Trademarks.

SECOND CAUSE OF ACTION
DESIGN PATENT INFRINGEMENT (35 U.S.C. § 271)

52. Plaintiff hereby re-alleges and incorporates by reference herein the allegations set forth in paragraphs 1–44 of this Complaint.

53. Defendants are and have been making, using, selling, offering for sale, and/or importing into the United States for subsequent sale or use, without authority, Infringing Products that infringe directly and/or indirectly the Design Patents.

54. For example, below is a comparison of figures from Plaintiff's Design Patents and images of one of Defendants' Infringing Products sold on a Defendant Internet Store.

Figures from U.S. Pat. No. D706,494 S

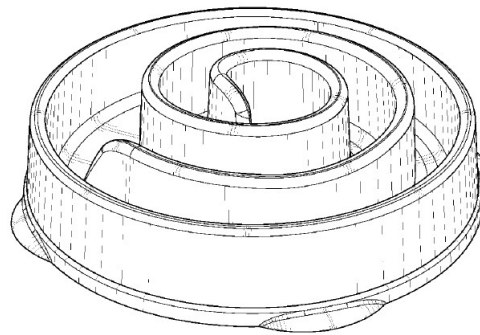

Exemplary Infringing Product Sold on Defendant Internet Store (DOE 62)

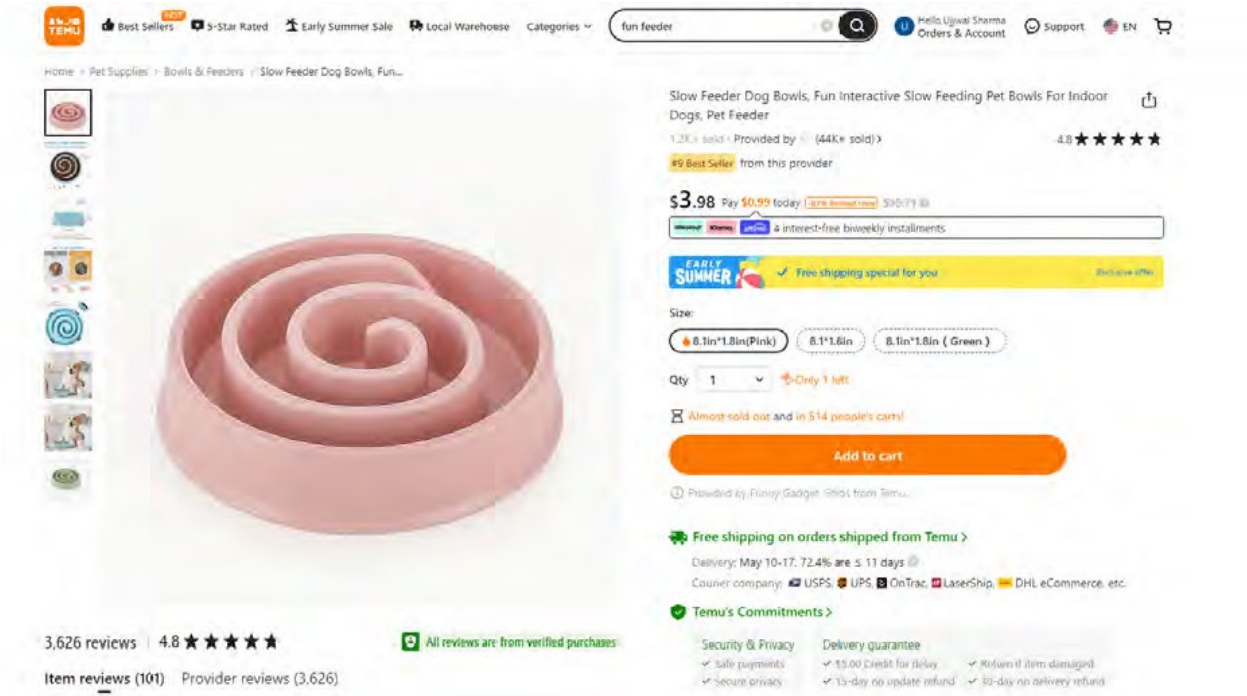

55. Defendants' activities constitute willful patent infringement under 35 U.S.C. § 271.

56. Defendants have infringed the Design Patents through the aforesaid acts and will continue to do so unless enjoined by this Court. Defendants' wrongful conduct has caused Plaintiff to suffer irreparable harm resulting from the loss of its lawful patent rights to exclude others from making, using, selling, offering for sale, and importing its patented designs. Plaintiff is entitled to injunctive relief pursuant to 35 U.S.C. § 283.

57. Plaintiff is entitled to recover damages adequate to compensate for the infringement pursuant to 35 U.S.C. §§ 284, 289, including Defendants' profits.

THIRD CAUSE OF ACTION **UTILITY PATENT INFRINGEMENT (35 U.S.C. § 271)**

58. Plaintiff hereby re-alleges and incorporates by reference herein the allegations set forth in paragraphs 1–44 of this Complaint.

59. Defendants are manufacturing, distributing, offering for sale, selling, and/or importing into the United States, unauthorized products which directly or indirectly infringe the Utility Patents both literally and under the doctrine of equivalents.

60. Defendants, without any authorization or license from Plaintiffs, have knowingly and willfully used and continue to use the Utility Patents in connection with the advertisement, distribution, offering for sale, and sale of Infringing Products into the United States and Florida over the Internet.

61. For instance, two examples of Defendants’ infringement of claims of the Utility Patents are described below:

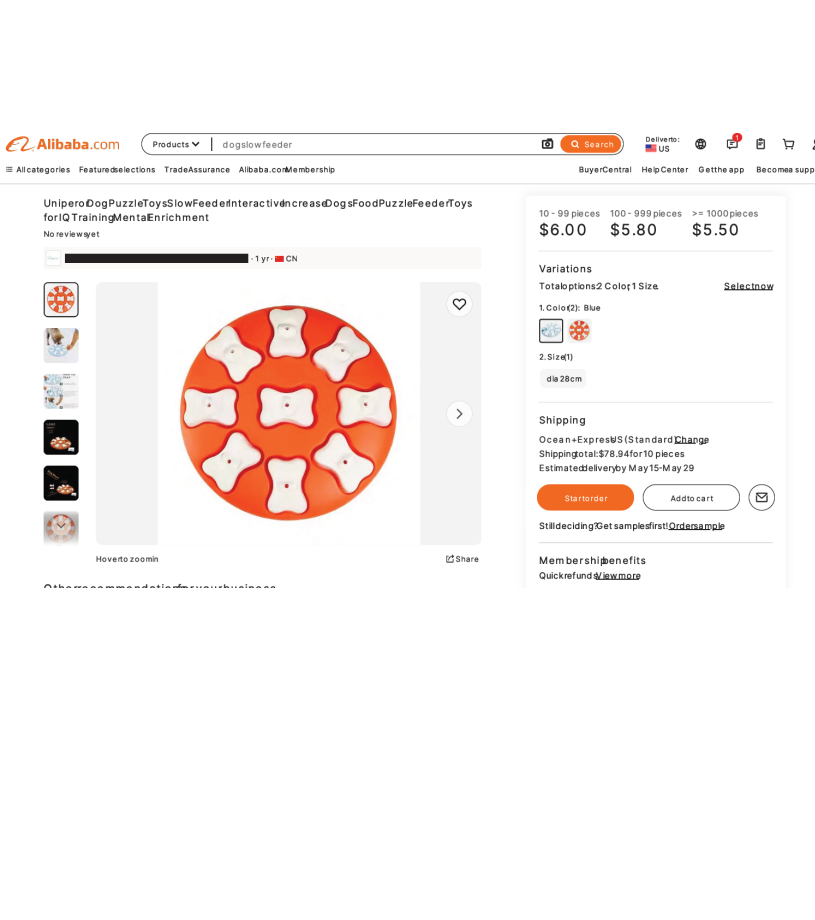
US Patent No. 8,316,804 Claim 1	Defendant’s Infringing Product (DOE 1)
<p>A pet board game including a game board comprising:</p> <p>a plurality of spaced apart tracks wherein, within each of said tracks there are two first cavities and a second cavity in between said first cavities extending below each of said tracks;</p> <p>two game covers being movably arranged along and engaging each of said tracks to facilitate covering each one of said cavities; and</p> <p>at least one pet board game detail having a body fitting into each of said tracks, wherein said body has a height, a width and a length arranged to be gripable by</p>	

<p>the mouth of a pet, said game covers comprising a body or body portion having outer walls comprising outer wall portions, a lower end and a top end, said body or body portion being arranged with an inwardly protruding void to form an open space within said body or body portion, wherein said void is formed by having a main portion of the total area exposed by said outer walls provided by wall portions having a limited wall thickness, and formed from a durable and washable polymeric material, and wherein said outer wall portions converge inwardly in a direction from said lower end toward the top end.</p>	
--	--

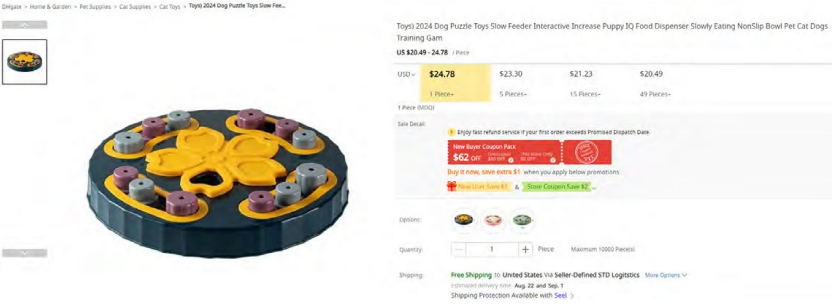
<p>US Patent No. 9,756,835 Claim 1</p>	<p>Defendant’s Infringing Product (DOE 7)</p>
<p>A multi-layered pet memory and agility exercise board game with a plurality of inset tracks with compartments therein, a slidable top, and moveable blocks comprising:</p> <p>a) A first plastic base piece with grooved tracks and inset compartments within the tracks, and which is attached via snap fit to a second plastic base piece with grooved track openings;</p> <p>b) A plurality of moveable circular blocks with holes in each center for treat insertion and for sliding said blocks within a track and a track opening in the base pieces;</p> <p>c) Indented compartments in the tracks to allow kibble or treats to be inserted therein and be covered by the blocks;</p> <p>d) A top spinning piece which slidably rotates on an axis to either impede or allow movement within the grooved tracks via a notch in one side of the top piece;</p> <p>e) At least three fin pieces which slidably rotate on an axis to conceal treats inserted in a track groove,</p>	

<p>and which fins may be alternately positioned to prevent the top spinning piece from moving; and</p> <p>f) Rubber or non-slip material feet located on the underside of the first base piece to prevent the board game from sliding, and wherein the non-slip material covers screws which attach the feet to the base.</p>	
---	--

62. Defendants have infringed the Utility Patents through the aforesaid acts and will continue to do so unless enjoined by this Court. Defendants' wrongful conduct has caused Plaintiffs to suffer irreparable harm resulting from the loss of their lawful patent rights to exclude others from manufacturing, distributing, selling, offering for sale, and/or importing the patented inventions as well as the loss of sales stemming from the infringing acts. Plaintiffs are entitled to injunctive relief pursuant to 35 U.S.C. § 283. Unless a preliminary and permanent injunction is issued enjoining Defendants and all others acting in concert therewith from infringing the Utility Patents, Plaintiffs will continue to be irreparably harmed.

63. Defendants' infringement of the Utility Patents in connection with the Infringing Products has been and continues to be willful.

64. Based on Defendants' wrongful conduct, Plaintiffs are entitled to injunctive relief as well as monetary damages and other remedies as provided by the Patent Act, including

recovering damages adequate to compensate for the infringement, as well as Defendants' profits pursuant to 35 U.S.C. § 289, and any other damages as appropriate pursuant to 35 U.S.C. § 284.

FOURTH CAUSE OF ACTION
FALSE DESIGNATION OF ORIGIN (15 U.S.C. § 1125(a))

65. Plaintiff hereby re-alleges and incorporates by reference herein the allegations set forth in paragraphs 1–44 of this Complaint.

66. Defendants' promotion, marketing, offering for sale, and sale of Infringing Products has created and is creating a likelihood of confusion, mistake, and deception among the general public as to the affiliation, connection, or association with Plaintiff or the origin, sponsorship, or approval of Defendants' Infringing Products by Plaintiff.

67. By using the Outward Hound Trademarks in connection with the sale of Infringing Products, Defendants create a false designation of origin and a misleading representation of fact as to the origin and sponsorship of the Infringing Products.

68. Defendants' conduct constitutes willful false designation of origin and misrepresentation of fact as to the origin and/or sponsorship of the Infringing Products to the general public under 15 U.S.C. §§ 1114, 1125.

69. Plaintiff has no adequate remedy at law, and, if Defendants' actions are not enjoined, Plaintiff will continue to suffer irreparable harm to its reputation and the goodwill of its brand.

PRAYER FOR RELIEF

WHEREFORE, Plaintiff demands judgment on all Counts of this Complaint and an award of equitable and monetary relief against Defendants as follows:

1. That Defendants, their affiliates, officers, agents, servants, employees, attorneys, confederates, and all persons acting for, with, by, through, under, or in active concert with them be temporarily, preliminarily, and permanently enjoined and restrained from:

a. making, using, offering for sale, selling, and/or importing into the United States for subsequent sale or use any products not authorized by Plaintiff and that include any reproduction, copy or colorable imitation of the design claimed in the Outward Hound IP, and specifically in the Outward Hound Patents;

b. further infringing the Outward Hound IP and damaging Plaintiff's goodwill;

c. aiding, abetting, contributing to, or otherwise assisting anyone in infringing upon the Outward Hound IP;

d. using the Outward Hound Trademarks or any reproductions, counterfeit copies, or colorable imitations thereof in any manner in connection with the distribution, marketing, advertising, offering for sale, or sale of any product that is not a genuine Outward Hound Product or is not authorized by Plaintiff to be sold in connection with the Outward Hound Trademarks;

e. passing off, inducing, or enabling others to sell or pass off any product as a genuine Outward Hound Product or any other product produced by Plaintiff that is not Plaintiff's or not produced under the authorization, control, or supervision of Plaintiff and approved by Plaintiff for sale under the Outward Hound Trademarks;

f. committing any acts calculated to cause consumers to believe that Defendants' Infringing Products are those sold under the authorization, control, or supervision of Plaintiff, or are sponsored by, approved by, or otherwise connected with Plaintiff;

g. further infringing the Outward Hound Trademarks and damaging Plaintiff's goodwill;

h. otherwise competing unfairly with Plaintiff in any manner;

i. shipping, delivering, holding for sale, transferring, or otherwise moving, storing, distributing, returning, or otherwise disposing of, in any manner, products or inventory not manufactured by or for Plaintiff, nor authorized by Plaintiff to be sold or offered for sale, and which infringe on the Outward Hound IP;

j. using, linking to, transferring, selling, exercising control over, or otherwise owning any online marketplace accounts, the Defendant Internet Stores, or any other domain name or online marketplace account that is being used to sell or is the means by which Defendants could continue to sell Infringing Products;

k. operating and/or hosting websites at the Defendant Internet Stores that are involved with the distribution, marketing, advertising, offering for sale, or sale of any product infringing on the Outward Hound IP or any reproduction, counterfeit copy, or colorable imitation thereof that is not a genuine Outward Hound Product or not authorized by Plaintiffs to be sold in connection with the Outward Hound IP; and

l. effecting assignments or transfers, forming new entities or associations or utilizing any other device for the purpose of circumventing or otherwise avoiding the prohibitions set forth in Subparagraphs (a) through (k).

2. Entry of an Order that the Marketplace Platforms, including without limitation Alibaba, Amazon, DHgate, eBay, Shein, Temu, and Walmart, and any other online marketplace account through which Defendants are selling Infringing Products:

a. disable and cease providing services for any accounts through which Defendants sell Infringing Products, including any accounts associated with the Defendants listed on Schedule A;

b. disable and cease displaying any advertisements used by or associated with Defendants in connection with their sale of Infringing Products; and

c. take all steps necessary to prevent links to the Defendant Internet Stores identified on Schedule A from displaying in search results, including, but not limited to, removing links to the Defendant Internet Stores from any search index.

3. That Plaintiff be awarded such damages as it shall prove at trial against Defendants that are adequate to compensate Plaintiff for Defendants' infringement of the Outward Hound Patents, but in no event less than a reasonable royalty for the use made of the invention by the Defendants, together with interest and costs, pursuant to 35 U.S.C. § 284;

4. That the amount of damages awarded to Plaintiff to compensate Plaintiff for infringement of Plaintiff's Outward Hound Patents be increased by three times the amount thereof, as provided by 35 U.S.C. § 284;

5. In the alternative, that Plaintiff be awarded all profits realized by Defendants from Defendants' infringement of Plaintiff's Outward Hound Patents, pursuant to 35 U.S.C. § 289;

6. That Defendants account for and pay to Plaintiff all profits realized by Defendants by reason of Defendants' unlawful acts herein alleged, and that the amount of damages for

infringement of the Outward Hound Trademarks be increased by a sum not exceeding three times the amount thereof as provided by 15 U.S.C. § 1117;

7. In the alternative, that Plaintiff be awarded statutory damages of not less than \$1,000 and not more than \$2,000,000 for each and every use of the Outward Hound Trademarks and statutory damages pursuant to 15 U.S.C. § 1117(c);

8. That Plaintiff be awarded their reasonable attorneys' fees and costs; and

9. Any and all other relief that this Court deems just and proper.

Dated: October 15, 2024

BOIES, SCHILLER & FLEXNER LLP

/s/ Nicole Fundora

Nicole Fundora (FL Bar No. 1010231)

100 SE 2nd Street

Suite 2800

Miami, Florida 33131

Tel: (305) 539-8400

nfundora@bsfllp.com

Attorney for Plaintiff The Kyjen Company, LLC